

UNIT 1: The Technological Process & Project Planning

1. Summarize the elements that affect Technology and briefly explain them.
2. Explain the steps that you should take into account in the technological process
3. Explain what a marketing plan is and its impact in society.
4. Explain which the three main functions in a company are.

Complete the words with the missing letters and order the sentences to describe the stages of the technological process.

- ___ Mat_rials _nd t_ols
- ___ P_ese_t
- ___ St_te the pr_bl_m
- ___ Pla_th_ con_tru_ti_n
- ___ S_arc_ for inf_rmat_on
- ___ B_ild the s_lu_ion
- ___ P_op_se se_eral s_lutio_s
- ___ D_strib_te t_e pr_du_t
- ___ S_lect a so_utio_
- ___ D_velop a budget
- ___ Ev_lua_e

Product design**Find the word that matches each definition and look for them in the word search.**

1. A method used to accomplish something: _____
2. The ability to create new ideas or products: _____
3. A rival person: _____
4. A technique for coming up with new ideas by allowing almost any idea to be brought up: _____
5. A similarity among different things: _____
6. Sentences expressed in a way that is seeking answers from someone else:

7. A payment system which uses a wireless technology that allows the client to pay with a credit card or mobile phone: _____
8. The process of creating new products or adapting existing products in order to improve them and place them on the market: _____
9. An association of people to create a business: _____

K G F R H R D V I E Z Q T S L
U G P C R E A T I V I T Y X P
L I Z E T B U W J B Y D V N L
J N H X M P F Q M J G X M I R
C C B R A I N S T O R M I N G
L O G M G I P F Y Z U K E N T
X M N M I C H G F N W F O O E
C P T T E Q G Q M B Y U A V C
O E J J A H S P O V N G N A H
M T L U M C M K C V T Y A T N
P I Q U E S T I O N S B L I I
A T X E N T H L K Y Y K O O Q
N O N H D D B D E U S A G N U
Y R D W F M R N Z S A I Y W E
V Z G Z J U G P E D S N J K O

Fill in the gaps using the terms below. Listen to the text to check your answers.

disuse - products- used - companies - perfectly - replaced - obsolescence- device
- meet

Technology is evolving rapidly. What was a cutting-edge _____ last year, might be an old-fashioned one today. New versions of _____ with more and better functions are coming out all the time. _____ create more efficient products in order to _____ the customer's needs and requirements. This means that products that have been _____ for some time have to be _____ with others that have new functions and that are more up-to-date. This leads to the _____ of old technological devices even if they still work _____ well: sometimes because of changes to the aesthetics or degree to which it's fashionable or trendy, other times because the new product offers more advantages... We call this technological _____. For example, we might buy the latest model of a mobile phone despite having another mobile phone that still works perfectly well.

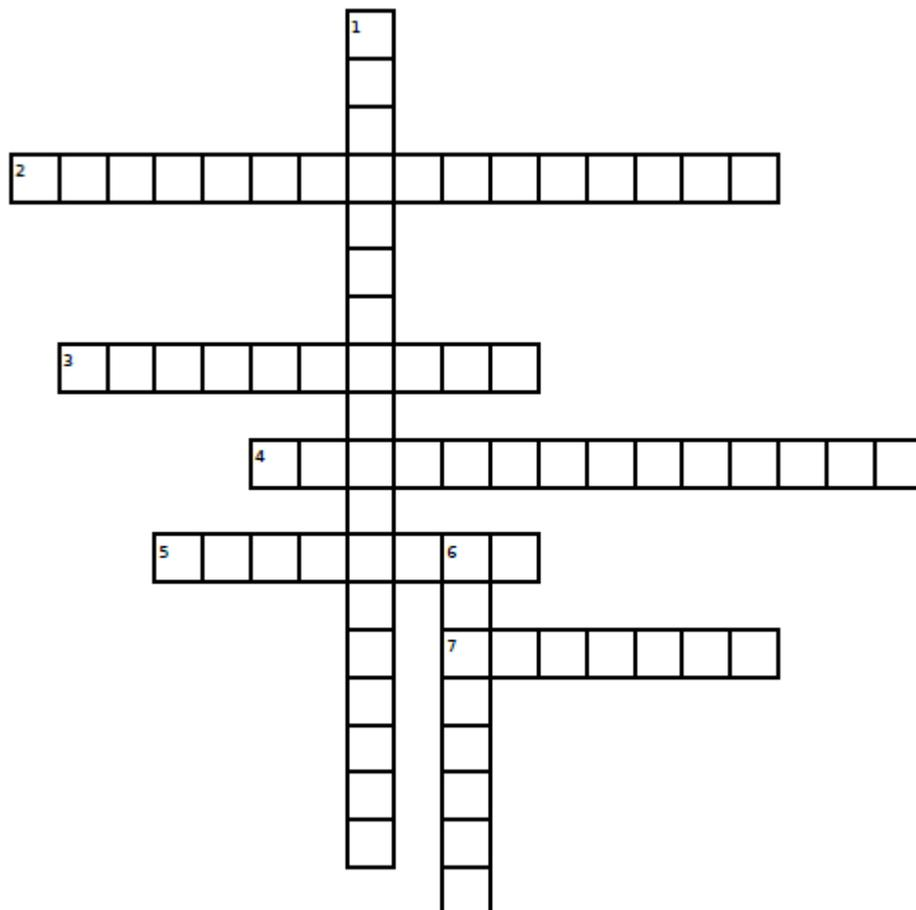
Solve the crossword.

Down:

1. The process of bringing various hardware or software elements together so that they can work as one.
6. The study of computer-controlled robots to perform different tasks.

Across:

2. A technology that adds digital elements to live objects by using a camera of a device.
3. The act of imitating a real situation.
4. The process of storing information on remote servers, which can be accessed at any time, from any device.
5. The technologies that make Industry 4.0 possible.
7. The large amount of information available on the internet.

Use the chart to classify the following sentences related to the impact of technological development in the environment.

Chemical processing systems that reduce chemical waste that harms the environment.

Contribution to the greenhouse effect.

Modes of transport that use greener fuels such as electric cars and bicycles.

Improving recycling processes.

Water pollution.

New forms of energy use that are more environmentally friendly.

Systems that enable greater control over energy consumption.

Reduction of the amount of ozone in the atmosphere.

Exhaustion of natural resources and deforestation.

Consequences of technological development	Improvements of technological development

--	--

UNIT 4: Electricity

1. Define and give examples (if possible) for the following concepts:
 - a. Generator
 - b. Load
 - c. Switching device
 - d. Voltage
 - e. Intensity
 - f. Resistance
 - g. Relay
 - h. Potentiometer
 - i. LDR
 - j. Capacitor
 - k. LED
2. Explain the types of circuit you know, and the differences between them.
3. Explain the types of current you know, and the differences between them.
4. Name and give examples for the effects of electric current.
5. Explain how a dynamo and an electric motor work.
6. Do the following activities from your textbook:
7. Fill the gaps in the chart above.

Intensity (A)	Voltage (V)	Resistance (Ω)
15 A	20 V	
5 A		20 Ω
	3 V	10 Ω
	4,5 V	3 Ω
12 A	6 V	

8. Calculate the total resistance in the next circuit.

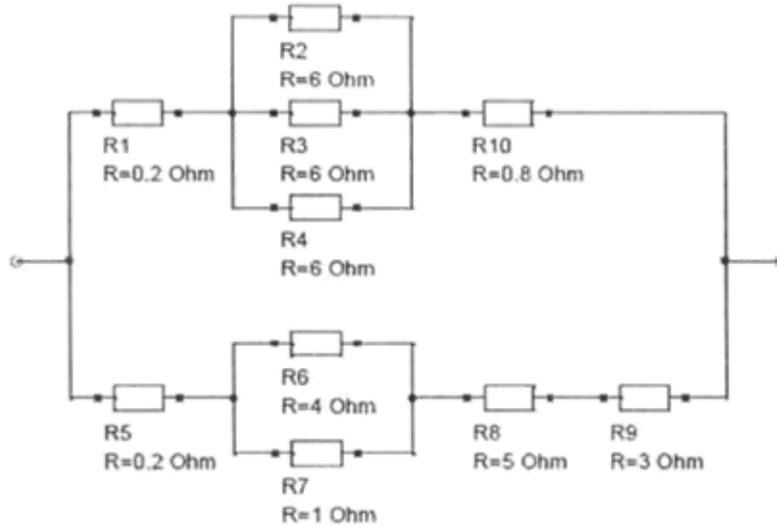

Complete the table with the words from below in order to distinguish between DC and AC current.

The flow of electrons changes direction. / Constant
Electrons flow in one direction / The voltage is constantly changing value. / Supplied by any power socket / Constant value of the voltage over time / Supplied by single- and multi-cell batteries

DC current	AC current

Electrical quantities

2. Solve the crossword.

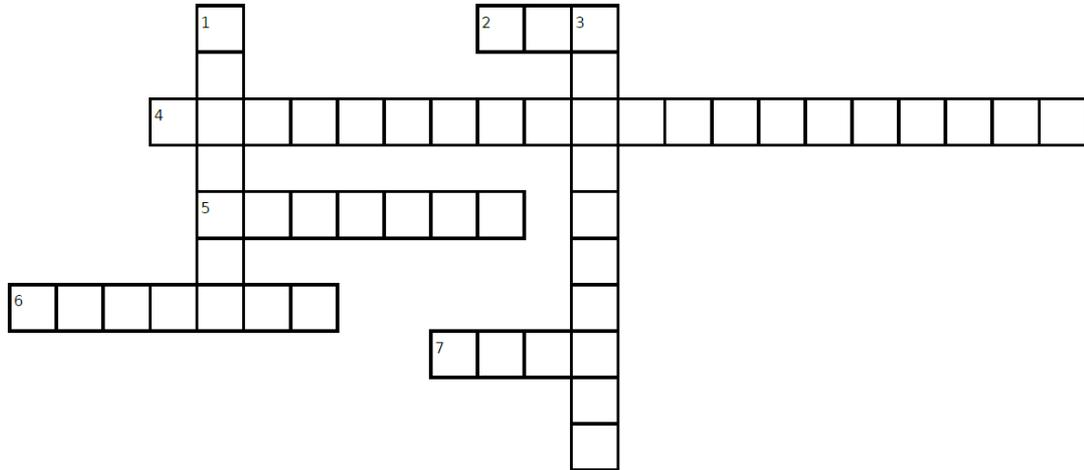

Down:

- 1 _____ = the difference in electrical charge between two points
3 _____ = a device that can be used as a voltmeter, ammeter and ohmmeter.

Across:

- 2 _____ = a unit represented by this symbol Ω
4 _____ = the opposition a material offers to the flow of electrical current.
5 _____ = commonly called amps.
6 _____ (or current intensity) = the quantity of electrons circulating through a conductor in a unit of time.
7 _____ = potential difference is measured with this unit

UNIT 5: Electrical and Electronic circuits

1. Solve the cryptogram.

A	B	C	D	E	F	G	H	I	J	K	L	M	N	O	P	Q	R	S	T	U	V	W	X	Y	Z	
20				15										19												

<u>E</u>	<u>E</u>						<u>O</u>																		<u>E</u>
15	12	15	6	17	8	19	22	13	6	6	13	8	6	25	13	17	3	8	15	12	24				
<u>O</u>		<u>E</u>					<u>O</u>							<u>E</u>		<u>A</u>	<u>E</u>							<u>A</u>	
19	22	3	15	2	13	6	19	22	18	25	6	17	13	11	15	2	20	17	15	8	13	20	12	3	
	<u>O</u>		<u>O</u>				<u>O</u>					<u>E</u>		<u>O</u>		<u>E</u>	<u>E</u>						<u>O</u>		
	17	19	6	19	22	17	8	19	12	17	9	15	2	19	11	15	2	15	22	17	19	4			
		<u>E</u>	<u>E</u>				<u>O</u>																		
		15	12	15	6	17	8	19	22	3															

2. Complete the table with the phrases from below to distinguish between DC and AC current.

- Signals with infinite values over time.
- Analogue factors (temperature, time, distance etc.)
- Signals with finite values
- Two voltage values (0 and 1)

Analogue circuits	Digital circuits

- Define and give examples (if possible) for the following concepts:
 - Sensor
 - Controller
 - Actuator
- Explain the differences between an open loop control system and a closed loop control system.
- Explain what the difference between the input and output is.

4. Explain what the differences between the digital and analogue variables are.
5. Explain how a DC motor, stepper motor and a servomotor work and which their differences are.
6. Explain how an ultrasound and an optical position sensor work.

3. Solve the crossword.

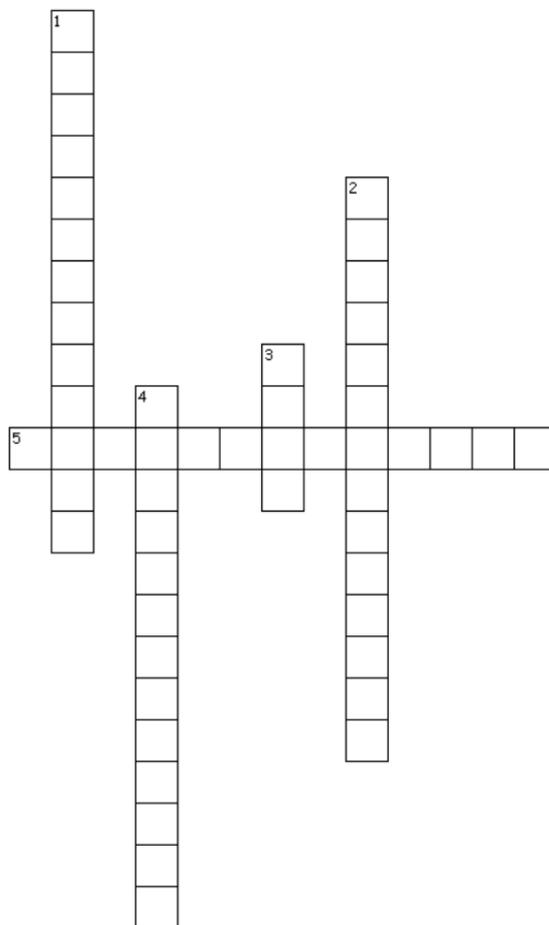

Across

- 5 Type of thermistor that when the temperature increases its resistance value also increases, and vice versa.

Down

- 1 Resistor whose value doesn't change.
- 2 Resistors whose value changes depending on the position of a contact, from zero to a maximum value.
- 3 Resistors whose value changes depending on the brightness of the light shining on them. They are also called photoresistors or photo-conductive cells.
- 4 Type of thermistor that when the temperature increases its resistance value decreases, and vice versa.

value decreases, and vice versa.

4. Match the terms in the three columns

TYPE OF COMPONENT	DEFINITION	UNIT
<ul style="list-style-type: none">• Inductor• Resistor• Capacitor	<ul style="list-style-type: none">• Component that opposes the flow of electric current.• Component that can store energy and later supply it to a circuit.• Component that stores energy in the form of a magnetic field when an electric current flows through it.	<ul style="list-style-type: none">• Henry (H)• Farad (F)• Ohm (Ω)

5. Identify and correct the false statements.

LED are semiconductors that only emit light when they are inversely polarised.

When transistors are operating in the active region, they act as amplifiers, which means the current flowing through the collector increases the current in the emitter. ___

In a LDR, resistance increases when the level of light is lower. ___

A NTC thermistor reduces its resistance as the temperature reduces. ___